

EBL5527-210
EBL5527-700





EBL5527-210



EBL5527-700

EBL5527-210

EBL5527-700



APPLICATIONS

- Lawns and gardens
- Paths
- Parking areas

TECHNICAL DETIALS

- PF: 0.9
- LED source: Lumileds 4014
- LED source quantity: 42
- Rated life: 50,000 hours
- Operating Temp: -20°C~+55°C

CONSTRUCTION

- Die-casting aluminum
- Tempered clear glass diffuser
- Epoxy polyester powder coating
- Silicone gasket
- Stainless steel screws
- Adjustable tilt angle: 30°
- Body color: Graphite (RAL7024)

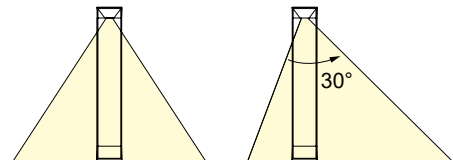

PHOTOMETRIC CURVES

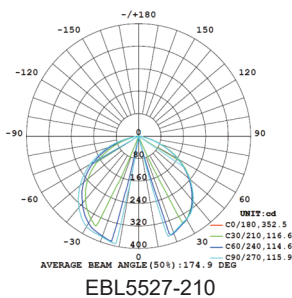

EBL5527-210

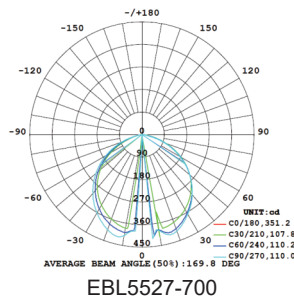

EBL5527-700

DIMENSION

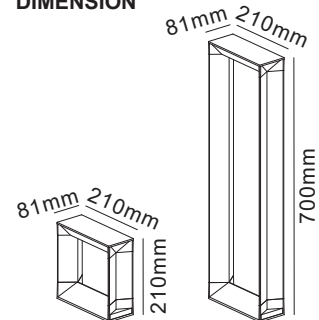

| Model | Input | Power | CCT | Lumen | CRI | BA |
|-------------|----------|-------|-------|-------|-----|------|
| EBL5527-210 | 220-240V | 8.5W | 3000K | 750lm | >80 | 174° |
| EBL5527-700 | 220-240V | 8.5W | 3000K | 750lm | >80 | 174° |